

Standard Applications:

- Palletizing

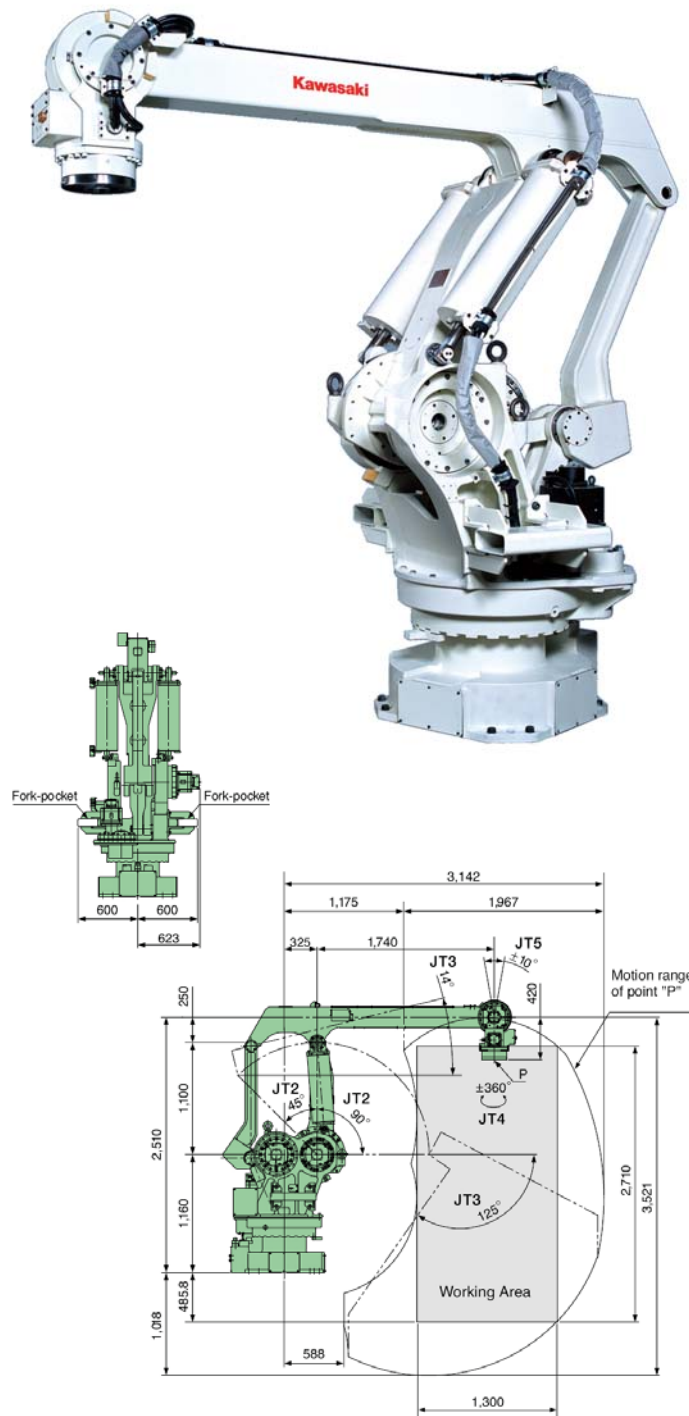

Arm Type	Articulated		
Degrees of Freedom	5		
Axes Work Envelope and Maximum Speed	Axis	Work Envelope	Maximum Speed
	Arm Rotation (JT1)	+180°	70° /s
	Arm Out-In (JT2)	+90° ~ -45°	65° /s
	Arm Up-Down (JT3)	+14° ~ -125°	45° /s
	Wrist Swivel (JT4)	± 360°	160° /s
	Wrist Bend (JT5)	± 10°	---
* Motion range of JT5 is ±10° to the vertical direction			
Working Area	1300 mm (width) 1300 mm (depth) 2710.4 mm (height)		
Palletizing Capacity	Approximately 600 cycles/hour (500 kg) On the condition that the robot moves 400 mm stroke upward-downward and 2000 mm stroke in the right-left direction.		
Repeatability	±0.5 mm (at the tool mounting surface)		
Maximum Payload	500 kg		
Maximum Speed	Max. 2000 mm/s in Linear Motion		
Maximum Wrist Inertia	250 kg*m ²		
Driving Motor	Brushless AC Servomotor		
Mass	2680 kg (excluding options)		
Color	Kawasaki Standard		
Installation	Floor mount		
Ambient Temperature	0- 45° C for manipulator		
Relative Humidity	35-85% non-condensing		
Pneumatic Piping	Built-in Pneumatic Piping (ø12 x 2 lines)		
	Valve Driving Lines for end-effector → 7 lines DC24V Spec. Sensor Lines for end-effector → 4 lines; DC24V + 0V		
Power/Signal Cable Length	7 m		
Options	Power/Signal Cable Length: 10 m, 15 m		
	Adjustable Mechanical Stopper for JT1, JT2, JT3		
	Limit Switch for JT1, JT2, JT3		
	Additional lines for sensor and valve		
	Gripper for box gripping		
	Gripper for bag gripping		
	Gripper using vacuum blower		
	Blower hose for end-effector (ø 1 inch — 1 line)		
Consult us about Maintenance Parts and Spare Parts.			